

**Modular Cooking Range Line  
 thermaline 90 - Half Module  
 Freestanding Electric Fry Top, 1 Side,  
 H=700- H3 -Marine**

ITEM # \_\_\_\_\_

MODEL # \_\_\_\_\_

NAME # \_\_\_\_\_

SIS # \_\_\_\_\_

AIA # \_\_\_\_\_



- 589836 (MCHXEADIDM)** Electric Fry Top with smooth chrome Plate, one-side operated - H3 - Marine
- 589838 (MCHZEADIDM)** Electric Fry Top with ribbed chrome Plate, one-side operated - H3 - Marine

### Short Form Specification

**Item No.** \_\_\_\_\_

Unit constructed according to DIN 18860\_2 with 20 mm drop nose top and 70 mm recessed plinth. Internal frame for heavy duty sturdiness in stainless steel. 2 mm top in 1.4301 (AISI 304). Flat surface construction, easily cleanable. THERMODUL connection system enables seamless worktop when units are connected and avoids soil penetrating. Chromium-plated mild steel cooking surface with non-stick finishing for optimal grilling. Powerblock heating system for optimal temperature distribution. Large drain hole allows draining of cooking juices into a large collector. Overheat protection switches off the supply in case of overheating. Standby function saves energy and quickly recovers maximum power. Metal knobs with embedded hygienic silicon "soft" grip enable easier handling and cleaning. IPX5 water resistant certification. Configuration: Freestanding, One-side operated.

### Main Features

- Large drain hole on cooking surface permits the draining of residual cooking juices into a large collector placed under the cooking surface.
- Overheat protection: the temperature sensor switches off the supply in case of overheating.
- Stainless steel high splash guards on the rear and sides of cooking surface.
- Units have separate controls for each half module of the cooking surface.
- All major components may be easily accessed from the front.
- THERMODUL connection system creates a seamless work top when units are connected to each other thus avoiding soil penetrating vital components and facilitating the removal of units in case of replacement or service.
- Metal knobs with embedded hygienic "soft-touch" grip for easier handling and cleaning. The special design of the controls prevents infiltration of liquids or soil into vital components.
- Large visible digital display manufactured in tempered glass to resist heat and chemicals, showing temperatures or power settings. The display also shows on/off status of the appliance and on/off status of the heating elements.
- Powerblock heating system for optimal temperature distribution.

### Construction

- 2 mm top in 1.4301 (AISI 304).
- Unit constructed according to DIN 18860\_2 with 20 mm drop nose top and 70 mm recessed plinth.
- Flat surface construction with minimal hidden areas to easily clean all surfaces
- IPX5 water resistance certification.
- Cooking surface in chromium-plated mild steel with non-stick finishing for optimum grilling results.
- Cooking surface to be completely smooth or completely ribbed.
- Internal frame for heavy duty sturdiness in stainless steel.

### Sustainability

- Standby function for energy saving and fast recovery of maximum power.

**APPROVAL:** \_\_\_\_\_



### Optional Accessories

- Connecting rail kit, 900mm PNC 912502
- Stainless steel side panel, 900x700mm, freestanding PNC 912512
- Portioning shelf, 400mm width PNC 912522
- Portioning shelf, 400mm width PNC 912552
- Folding shelf, 300x900mm PNC 912581
- Folding shelf, 400x900mm PNC 912582
- Fixed side shelf, 200x900mm PNC 912589
- Fixed side shelf, 300x900mm PNC 912590
- Fixed side shelf, 400x900mm PNC 912591
- Endrail kit, flush-fitting, left PNC 913111
- Endrail kit, flush-fitting, right PNC 913112
- Scraper for smooth plates (only for 589836) PNC 913119
- Scraper for ribbed plates (only for 589838) PNC 913120
- Endrail kit (12.5mm) for thermaline 90 units, left PNC 913202
- Endrail kit (12.5mm) for thermaline 90 units, right PNC 913203
- Stainless steel side panel, left, H=700 PNC 913222
- Stainless steel side panel, right, H=700 PNC 913223
- T-connection rail for back-to-back installations without backsplash (to be ordered as S-code) PNC 913227
- Endrail kit, (12.5mm), for back-to-back installation, left PNC 913251
- Endrail kit, (12.5mm), for back-to-back installation, right PNC 913252
- Endrail kit, flush-fitting, for back-to-back installation, left PNC 913255
- Endrail kit, flush-fitting, for back-to-back installation, right PNC 913256
- Side reinforced panel only in combination with side shelf, for freestanding units PNC 913260
- Side reinforced panel only in combination with side shelf, for back-to-back installations, left PNC 913275
- Side reinforced panel only in combination with side shelf, for back-to-back installation, right PNC 913276
- Set of 2 flanged feet for Marine appliances (only for 589838) PNC 913295
- Filter W=400mm PNC 913663
- Stainless steel dividing panel, 900x700mm, (it should only be used between Electrolux Professional thermaline Modular 90 and thermaline C90) PNC 913672
- Stainless steel side panel, 900x700mm, flush-fitting (it should only be used against the wall, against a niche and in between Electrolux Professional thermaline and ProThermetic appliances and external appliances - provided that these have at least the same dimensions) PNC 913688

### Recommended Detergents

- C41 HI-TEMP RAPID DEGREASER, PNC 0S2292
- 1 pack of six 1 lt. bottles (trigger incl.)



**Electrolux**  
PROFESSIONAL

Modular Cooking Range Line  
thermaline 90 - Half Module Freestanding  
Electric Fry Top, 1 Side, H=700- H3 -Marine

### Electric

Supply voltage: 440 V/3 ph/50/60 Hz  
Total Watts: 5.1 kW

### Key Information:

Cooking Surface Depth: 615 mm  
Cooking Surface Width: 300 mm  
Working Temperature MIN: 80 °C  
Working Temperature MAX: 280 °C  
External dimensions, Width: 400 mm  
External dimensions, Depth: 900 mm  
External dimensions, Height: 700 mm  
Storage Cavity Dimensions (width): 340 mm  
Storage Cavity Dimensions (height): 330 mm  
Storage Cavity Dimensions (depth): 740 mm  
Net weight: 91 kg  
Configuration: On Base;One-Side Operated  
Cooking surface type:  
589836 (MCHXEAD1DM) Smooth  
589838 (MCHZEAD1DM) Ribbed  
Cooking surface - material: Chromium Plated mild steel mirror

### Sustainability

Current consumption: 7 Amps

Front

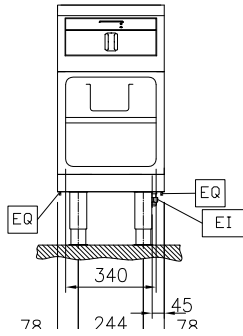

Side

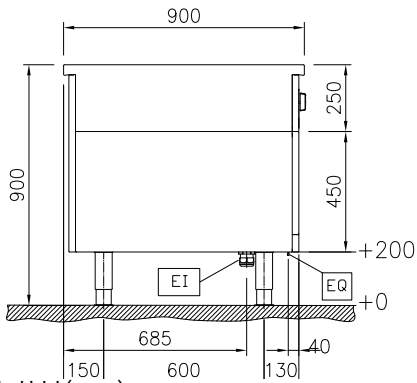

EI = Electrical inlet (power)  
 EQ = Equipotential screw

Top

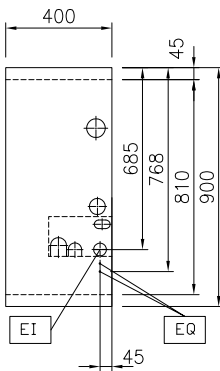

Front

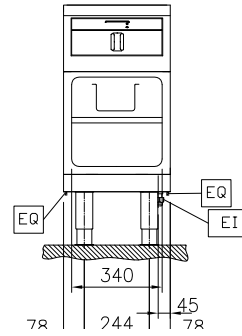

Side

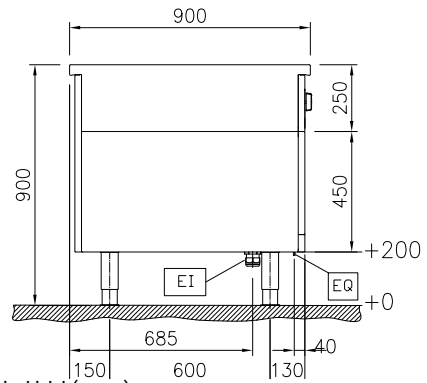

EI = Electrical inlet (power)  
 EQ = Equipotential screw

Top

